

# INSTRUCTIONS MANUAL PROTECTION AND CONTROL PANELS FOR THREE-PHASE SUBMERSIBLE PUMPS

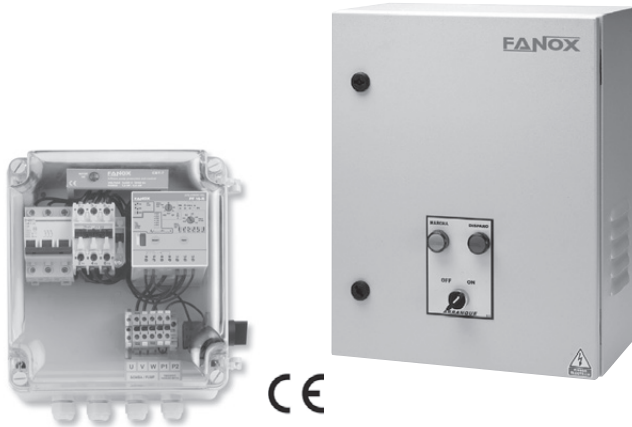

Models	Code 3x230V	Code 3x400V	Motor 3 x 400V 50/60 Hz	
			HP	kW
CBT-1	12301-230	12301-400	0.5 - 1	0.37 - 0.75
CBT-2	12302-230	12302-400	1.5 - 2	1.1 - 1.5
CBT-5	12305-230	12305-400	3 - 5.5	2.2 - 4
CBT-7	12307-230	12307-400	7.5	5.5
CBT-10	12310-230	12310-400	10	7.5
CBT-15	12315-230	12315-400	15	11
CBT-20M	12316-230	12316-400	20	15
CBT-25M	12317-230	12317-400	25	18.5
CBT-30M	12318-230	12318-400 </td <td>30</td> <td>22</td>	30	22
CBT-40M	12319-230	12319-400	40	30
CBT-50M	12320-230	12320-400	50	37
CBT-60M	12332-230	12332-400	60	45

### Main description

#### • Protections:

- $\cos \varphi$  Dry running by power factor ( $\cos \varphi$ ).
- $I >$  Overload with thermal memory.
- Phase loss or phase unbalance.
- Incorrect phase sequence.
- Short-circuit.

- Manual/remote or automatic reset (adjustable from 2 to 75 m).
- Indicates cause of tripping.
- Control point for pressure switch, buoy, programmer...

### Parts

- Case:
  - From 0,5 to 15 HP: Plastic case with transparent lid, 230x250x150mm, IP554
  - From 20 to 25 HP: Metallic case 500x400x200mm, IP55
  - From 30 to 40 HP: Metallic case 600x400x200mm, IP55
  - From 50 to 60 HP: Metallic case 600x500x200mm, IP55
- Circuit breaker 3P or 3P+N
- Fanox PF electronic relay.
- Contactor.
- Switch ON/OFF
- Signalling LED's
- Connecting strip.
- Cable glands.

### Connexion diagram

To prevent electrical shocks whilst installing or operating the relay, disconnect the power supply.

1. Check that the auxiliary voltage supply is correct.
2. Connect the wires of the motor to U, V and W. Check that the phases have been placed in the correct sequence.
3. If terminals P1 and P2 are not going to be used for a pressure switch, a buoy, a timer, etc., they must be bridged with a cable.
4. Connect the power input to the terminals of the circuit breaker. Check that the phases have been placed in the correct sequence if not, the LED shall remain lit. In this case, two of the three network lines of the circuit breaker must be disconnected (e.g. R and T) and their position must be changed to establish the correct sequence.

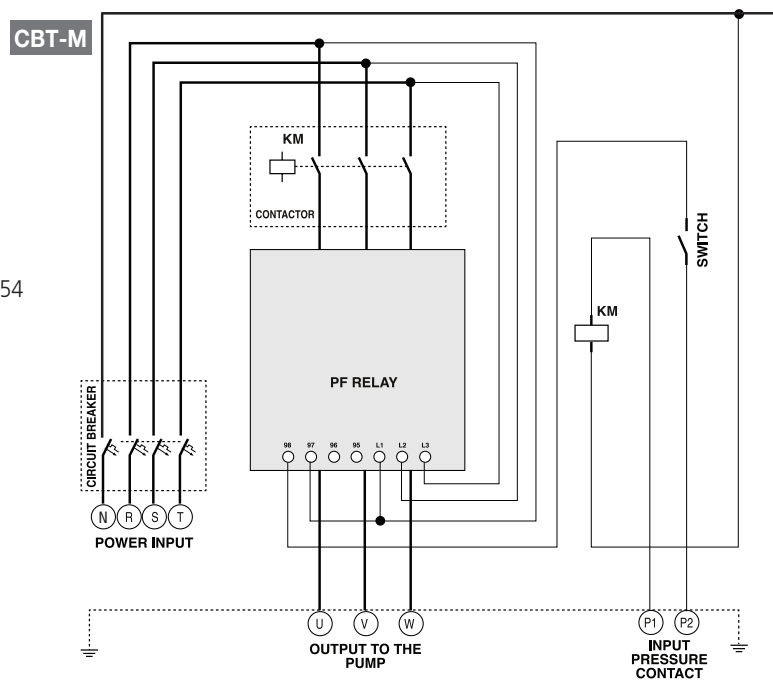
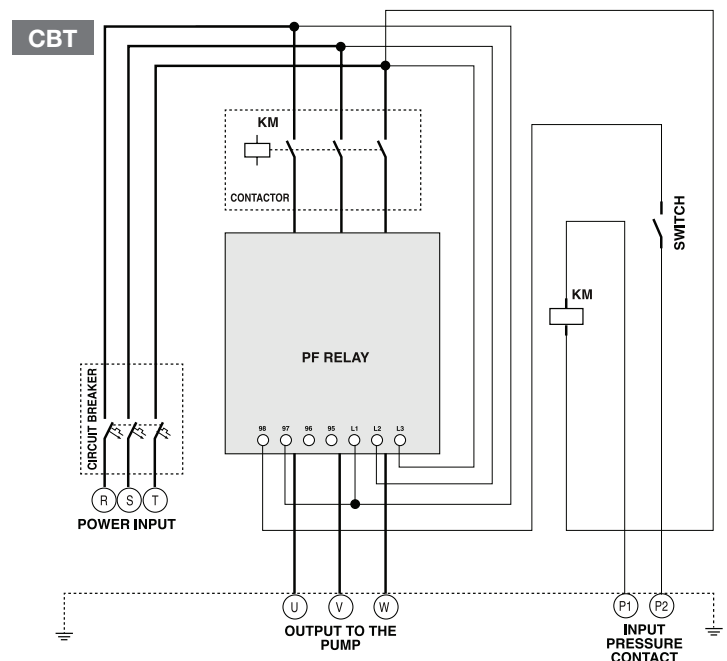

## Settings

Depending on the characteristics of the motor and of the installation, some simple adjustments must be made to the PF relay.

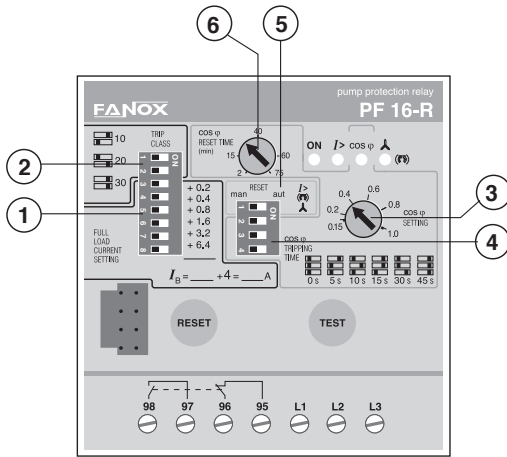

Signalling

**ON** : relay in service  
**I>** : Tripping due to overload  
**cos φ** : Tripping due to underload

: Tripping due to phase loss or unbalance  
 : Tripping due to incorrect phase sequence

### 1 Current setting $I_B$ "Full load current"

This adjustment is to be made according to the nominal current of the motor  $I_N$  indicated in its characteristics plate (see panel)

In order to calculate the  $I_B$  to be adjusted in panels CBT-1 and CBT-2, the  $I_N$  has to be multiplied by 4 and 2 respectively.

In the rest of the cases, the  $I_B$  to be adjusted must be the same as the  $I_N$  of the motor.

Ref.	$I_B$ to be adjusted
CBT-1	$I_N \times 4$
CBT-2	$I_N \times 2$
CBT-...	$I_N$

- With all the micro-switches to the left (OFF), the set current is the basic current of the relay (4A for the PF 16-R and 16A for the PF 47-R)
- When we place a micro-switch to the right (ON), we add its value to the basic current. To obtain the necessary  $I_B$ , these values must be combined.

Examples:

**CBT-2 Panel.**

Supposing that the nominal current of the motor, indicated on its characteristics plate is 3 A.

The current to be set will be:  
 $I_B = I_N \times 2 = 3 \times 2 = 6 \text{ A}$   
 $6 \text{ A} = 0,4 + 1,6 + 4$

**CBT-7 Panel**

$I_N = 12 \text{ A}$   
 $I_B = I_N = 12 \text{ A}$   
 $12 \text{ A} = 1,6 + 6,4 + 4$

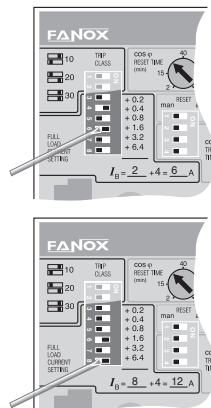

### 2 Trip class setting "Trip class"

The different trip classes allow to adapt the overload protection to the different applications of motors.

For submersible pumps, adjust to class 10 (recommended value).

Place the first micro-switch to the right (ON) and the second to the left (OFF).

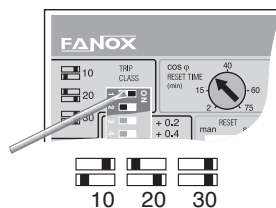

### 3 Underload setting "cos φ setting"

The adjustment of the underload trip level by  $\cos \phi$  is made through a potentiometer graduated from 0.15 to 1.0.

#### 3.1 Quick adjustment:

a) If the pump is adequately dimensioned, the recommended value for the adjustment of the  $\cos \phi$  is 0.5. This applies in the majority of cases. Adjust the potentiometer "cos φ setting" to 0,5

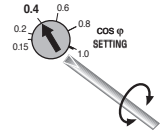

b) If the power of the motor is excessively dimensioned and during its functioning, unwanted trips should occur, the  $\cos \phi$  adjusted factor should be reduced to 0.4.

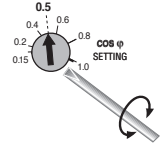

#### 3.2 Step-by-step adjustment:

If the above mentioned  $\cos \phi$  values are unknown, the underload trip setting can be made in the following way:

1. Set the underload trip delay to zero by moving the three dipswitches to the left (trip delay).
2. Using the potentiometer ( $\cos \phi$  setting), set the  $\cos \phi$  value to the minimum 0,15.
3. Start up the motor and run it with the minimum estimated load.
4. Slowly turn the  $\cos \phi$  potentiometer clockwise until the relay trips and the  $\cos \phi$  LED lights up.
5. Turn the  $\cos \phi$  potentiometer anticlockwise until the  $\cos \phi$  is set at approximately 30% less than the previous value (point 4).
6. Set the underload trip delay using the 3 corresponding dip switches.

### 4 Cos φ trip delay setting "cos φ tripping time"

Recommended time 5 seconds.

Place the first micro-switch to the right (ON) and the second and third to the left (OFF).

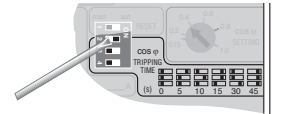

### 5 Reset mode setting "Reset"

To choose this mode, place the gliding micro-switch in "auto" position, to the right.

After **I>** trip, the reset will occur after 4 minutes approximately, uninterruptedly, until normal conditions are recovered.

After or trip, the reset will occur after 4 minutes, only if normal conditions have been recovered.

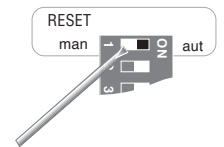

### 6 Cos φ Reset time setting

The adjustment of the reset time is made through the potentiometer ⑥ graduated from 2 to 75 minutes. Following the trip by  $\cos \phi$ , the reset will occur after the period of time adjusted.

